

Control System for the Four-Shot X-ray Machine

A. A. Erfort, A.V. Saushkin, V.F. Feduschak

Institute of High-Current Electronics, SB, RAS, 2/3 Akademicheskoy Ave., 634055 Tomsk, Russia

Abstract – The problems of the integrated automation of the technical means of the pulse four-shot X-ray machine are discussed. The explanation of the choice of a computer control system and the obtained results are considered.

1. Introduction

The automation object is the system, composed of four X-ray machines, generating the single pulses of radiation in various instants. Time intervals between the shots can vary from start-up to start-up. This developed for the Institute of the Hydrodynamics SB RAS is intended for the investigation of the explosive processes by means of the analysis of the photos, obtained after the radiograph of the object in a X-ray spectrum in various instants.

Each machine represents the high-current generator, which has a vacuum diode as a load, intended for deriving of an X-radiation. The design parameters of the generator are the following: an output voltage is 700 kV, a diode current is 1,5 – 1,8 kA, a pulse duration on a halfwidth is 100 nanoseconds. A kernel of the generator is the pulse transformer, transformed a discharge current of the capacitors flowing on its primary coil in a high-voltage pulse. The discharge of the capacitors occurs under the action of a high-voltage pulse driver (~50 kV), which is given to the gap arrester, inside of which the increased air pressure is maintained.

2. Tasks

Starting from the specificity of the machine, the necessity of an automatic control system is caused by the following reasons:

1) The Time between arrival of the triggering signal from the controlled process and actuation of each of four machines can be varied in any way from units of microseconds up to hundreds microseconds and units of milliseconds. A high accuracy of the assignation of the given time intervals is required, as machine realizes the shooting of the high-speed explosive set up processes in an X-ray range.

2) The presence in each machine of the several systems, requiring control and automatic maintenance of the parameters. Among these are: high-voltage power supplies for the charging of the capacitors and the starting generators, the drive-pulse generators, systems of pressure maintenance in the gap arrester.

3) Necessity of the safe and stable operation of the system, eliminating any actuations or absence of the actuation in required instants.

Besides the customer had been mounted the following demands to a control system and synchronization:

- the system should be steered by only one operator;
- the amount of operations at preparation for start-up should be minimum;
- the automatic maintenance and indication of the specified parameters of their values during the work should be ensured.

Hence the solution on necessity of use a personal computer as the basic controls means is accepted.

3. The block diagram of a control system

According to the tasks the block diagram of a control system has been developed for the set up. The block diagram of a control system is shown in a Fig. 1.

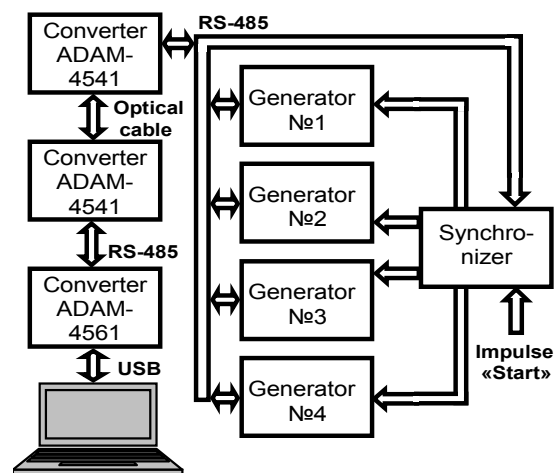

Fig. 1. Block diagram of the complex of automation systems of the X-ray machine

Control functions by all system are assigned to a personal computer as a whole, or by separate blocks if necessary their inspections and customization. The commands from the computer, which is placed in the control center, come to the machines, allocated in an experimental room, via the fiber-optical communication line. As a converter the blocks of series ADAM-4000 of the company Advantech are used. Use of the optical communication channel, allows to eliminate the electromagnetic noises from the working

machines, which appear in long wires. Inside from each generator separate devices are hooked up to the general two-wire bus of the interface RS-485. To eliminate errors in sending and receiving of a commands and data, each controller has the unique address which can be changed if necessary on a command from a computer.

The pulse drivers for each generator move from the synchronizer, in instants in advance mounted from a personal computer after inflow of an pulse from the examined process.

4. Implementation of control units by the generator

The composition of each of four generators includes some units requiring automatic steering and monitoring. It, first of all high-voltage power supplies, units of a drive-pulse shaping, and also controllers of an air pressure in dischargers.

For the charging of the storage capacitances and the drive-pulse generator the small-size high-voltage power supplies with following parameters specially have been developed:

- 1) The Band of an output voltage: 0 ... +50 kV;
- 2) The Output current: not less than 100 Microamperes;
- 3) Instability of an output voltage: $\geq 1,0\%$;
- 4) Manual control and indication of meaning of an output voltage;
- 5) Automatic steering of a source from a personal computer by means of link with it through interface RS-485.

The main control element in the power supply is the microcontroller ATmega-16 of corporation Atmel. It 8-bit single-chip micro-computer with RISC-architecture (Restricted Instruction Set Computer).

In Fig. 2. the photo of one of power supplies and the synchronization block of the activation of the machines is presented. The synchronization block ensures the output of the trigger pulses to the all every machine with the delay set in advance from a computer. The parameters of the block are the following:

- 1) The delay time can be set over the range from 300 nanoseconds up to 3 seconds;
- 2) The discretization of a step of a time delay installation of 50 nanoseconds over the range from 300 nanoseconds up to 1 usec and further with a step of 100 nanoseconds, separately for each of four channels;
- 3) The possibility of the manual start-up for the inspection and customizations of the system and a normal mode of the trigger at coming in of the pulse driver from the examined process are provided.

For a stable operation of the generators it is necessary to maintain the constant increased air pressure in starting dischargers with high accuracy. For this purpose the special block of the pressure control was developed. Its scheme and hooking up are shown in a Fig. 3.

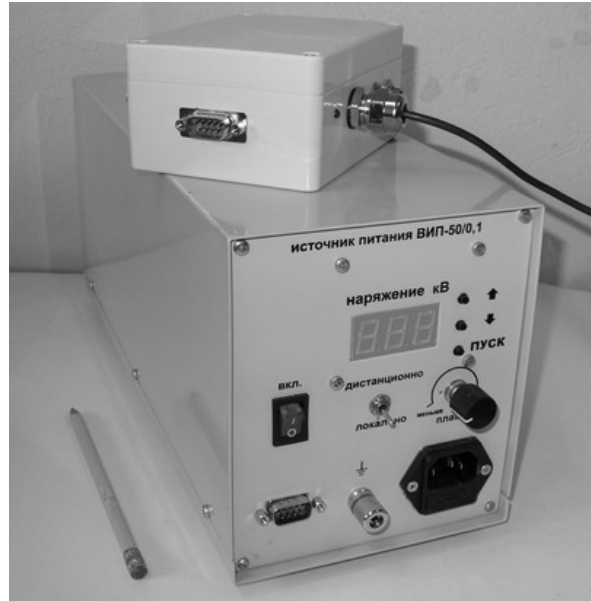

Fig. 2. Appearance of the power supply and the synchronizer

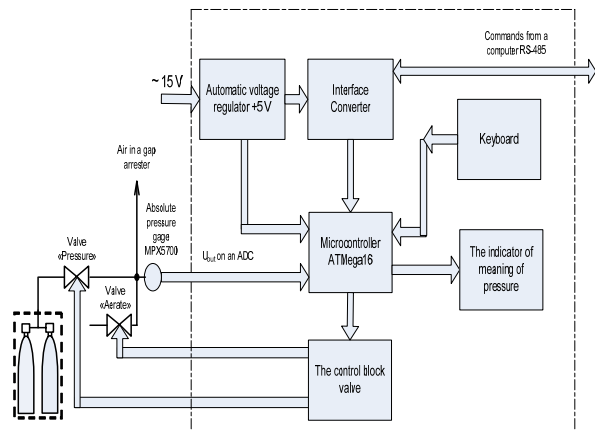

Fig. 3. The flowchart of hooking up of the control unit of pressure

The controller allows mounting required value of the pressure in air system from the keyboard on the block, or distantly by a command from a computer. The maximum overpressure – 5 atmospheres. Except for a data transfer in a computer, indication of working meaning of pressure is carried on the indicator which is being on a front panel of the block.

5. The software

For a personal computer under operating system Windows, the control program, realizing all necessary functions for the control of the 4-shot X-ray machine has developed. As a programming language the Delphi 7 has chosen.

The control program allows setting all necessary parameters for operation of all systems of generators, namely:

- a level of an output voltage of all power supplies;
- a required air pressure in the dischargers;
- delay time of actuation of each of the machines relative to impulse of activation.

During the operation all necessary values of the magnitudes and the information on a working state of the components are displayed on the screen of the PC. The program carries on the recording of the process of operation, after completion the file of the report is saved on a disk of a computer.

In Fig. 4. the view of one of the windows of the program in which data about work of high-voltage power supplies are displayed is presented.

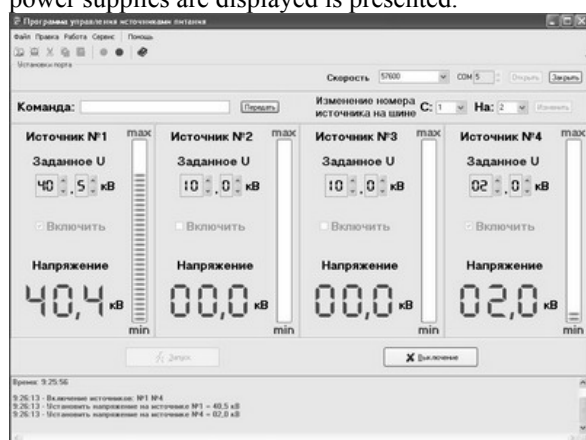

Fig. 4. Window of the control program

The programs for the AVR microcontrollers of the control blocks have been developed in the AVR- assembler programming language. Due to it was possible to gain rather compact and the main thing fast in realization machine code. Greater speed of operation of the controllers has allowed gauging and regulating output parameters very precisely.

6. Conclusion

On the done operation on creation of system of automated control by the pulsing four-frame roentgen machine it is possible to formulate following outputs:

- 1) During work common block diagram of a management system and synchronization has been developed for the apparatus;
- 2) The circuit diagrams have been developed and the bread board patterns of the power supplies, control units of pressure, the synchronization block are made and their trials on one apparatus are led;
- 3) For the microcontrollers steering, which control the separate systems of the machine, control programs have been written and debugged;
- 4) For the control of system from a computer the separate programs for each subsystem and the common program for control of all machines have been written;
- 5) The original network report allowing in real time to keep in contact with all subordinated control units and to steer them was developed;
- 6) The alternative of arrangement and arranging of electronic blocks is offered.

References

- [1] A.V. Saushkin, A.A. Erfort, V.F. Feduschak, V.K. Petin, N.A. Ratakhin, S.V. Shljakhtun, N.V. Zharova., in: *Proc. 14th Symposium on High Current Electronics*, Tomsk, Russia, 2006.
- [2] *Automation and programming techniques for microprocessor devices/* A.M. Belov, E.A. Ivanov, L.L. Murenko. M.: Energoatomizdat, 1988.
- [3] *Delphi 7 /* Ed. by A.D. Khomenko. – St-P.: BHV-St-Petersburg, 2003. – 1216 .: il.
- [4] *Programming of microprocessor devices: Collection of laboratory work/* D.V. Andreev. Ulianovsk: UISTU, 1994.